

## Plasma Direct Installation Instructions for Mitsubishi Lancer Evolution X

Thank you for your purchase. Please read this instruction carefully for a proper and safe installation.

### Safety Instructions



1. Installation should be made only on designated vehicles and models.
2. Never modify or dismantle this product.
3. The vehicle should be on a flat surface, with tires blocked to prevent the vehicle from rolling.
4. The engine should be off and completely cooled. Be sure the ignition key is not inserted.
5. The negative terminal from the battery should be disconnected. Note that this may cause the security alarm to activate. Consult the vehicle owner's manual to prevent this from occurring.
6. The engine should be in good operating condition. Any sign of defects should be corrected before installation.
7. Make sure you have adequate ventilation before running the engine.
8. Installation should be performed by a professional mechanic.
9. If the engine performance was previously boosted through modification of the ignition timing or air/fuel ratio, it may require readjustment following installation of the product.
10. If any defects are found in the product, discontinue using it immediately and contact the dealer where you purchased the product or us.

### Parts Included

Plasma Direct coils 4P

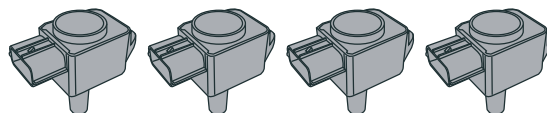

### Installation Procedure

- 1 Disconnect the negative (minus) battery terminal.  
Note: It takes approx. 20 minutes to reset the ECU.
- 2 Remove the engine cover to expose the ignition coils, so that you can start the installation of the Plasma Direct coils.

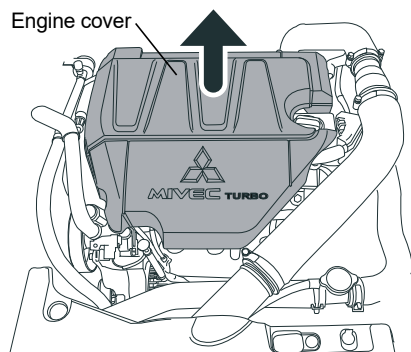

- 3 Disconnect the coil connectors, and remove the ignition coils from the engine.

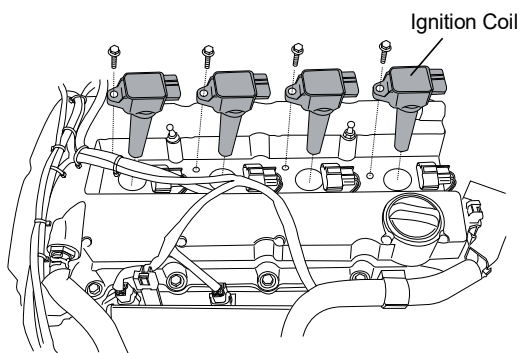

- 4 Remove the spark plug boots from the ignition coils, and attach them to the Plasma Directs.

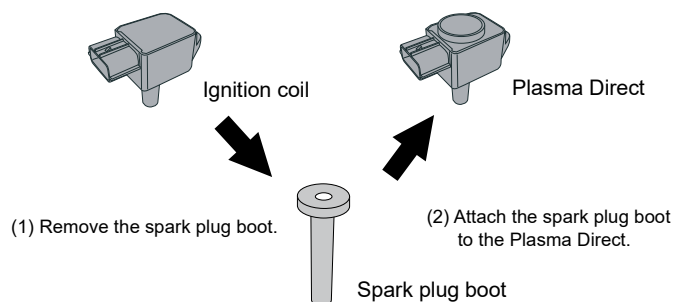

- 5 Install the Plasma Directs to the engine, and connect the coil connectors.

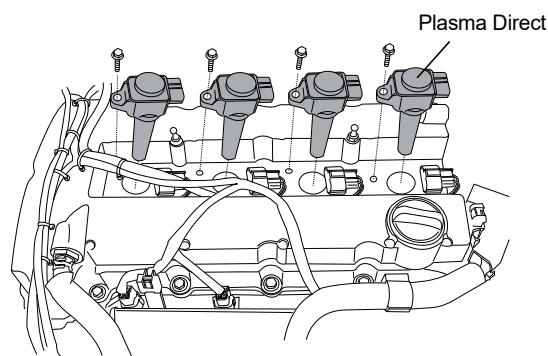

- 6 Place the engine cover back onto the engine.

PD4003302R  
Mitsubishi 1/1